

u-blox Neo-6M GPS Module

User Manual



Content

Features	3
Parameters	3
Electrical	3
How to use	4
Pins definition	4
External active antenna	4
Connect to 3.3V Micro-controller Board	5
Connect to 5V Arduino Board	5
Connect to PC	5
NMEA Protocol	6
Reference documentation	6
Using u-center	6
Note	6
Kit Contents	6
Warranty	7

u-blox Neo-6M GPS Module

1. Features

- a.) Standalone GPS receiver.
- b.) Base on U-BLOX NEO-6M modular, it is compact and excellent performance.
- c.) Built in ceramic antenna and MAXIM 20.5dB high gain LNA chip, strong satellite searching capabilities.
- d.) Able to set parameters via the serial port and save in EEPROM.
- e.) Comes with IPX interface, you can connect a variety of active antenna, strong adaptability.
- f.) It is compatible with 3.3V level, easy to connect to any Micro-controller.
- g.) Comes with a rechargeable backup battery for storing satellite searching data.
- h.) The module's interface is RS232(TTL level, 3.3V for 'H', 0V for 'L'), it supports 4800、9600、19200、**38400 (default)** 、57600、115200、230400 baud rates.

*Note: After the main power is off, the backup battery can sustain half an hour for storing satellite data, so that it take shorter time for positioning on hot or warm start.

2. Parameters

Items	Description	
Interface	TTL level, 3.3V.	
Receiver type	50-channel u-blox 6 engine GPS L1 C/A code SBAS: WAAS, EGNOS, MSAS	
Navigation update rate	5Hz	
Accuracy	Position	2.5 m CEP
	SBAS	2.0 m CEP
Acquisition	Cold starts:	27s
	Aided starts:	< 3s
	Hot starts:	1s
Sensitivity	Tracking:	-162 dBm
	Cold starts:	-147 dBm
	Hot starts:	-156 dBm

3. Electrical

Items	Description
Operating Voltage	DC3.3V~5.0V
Operating Current	45mA
TXD/RXD Impedance	510 ohm

4. How to use

4.1 Pins Definition



Pin #	Pin Name	Description
1	PPS	Time Pulse output
2	RXD	Rx. Connect to Micro-controller's Tx pin.
3	TXD	Tx. Connect to Micro-controller's Rx pin.
4	GND	Connect to ground.
5	VCC	Connect to 3.3V ~ 5V.

PPS pin is connected to a status indicator LED: PPS, this pin is connected to the port UBLOX NEO-6M TIMEPULSE module, the output characteristics of the port can be set by the program. PPS pin, by default, there are two states:

- (i) Always on, which means that the module has started to work, but have not yet achieved positioning.
- (ii) Flashing (100ms off, 900ms bright), which means that the module has been successful positioning.

Thus, by PPS indicator, we can easily determine the current state of the module, easy to use.

4.2 External active antenna

There is an IPX interfaces for connecting to an external active antenna to further improve the reception capability of the module. So that we can do the indoor positioning where the module is at indoor and active antenna at outdoor.



4.3 Connect to 3.3V Micro-controller Board

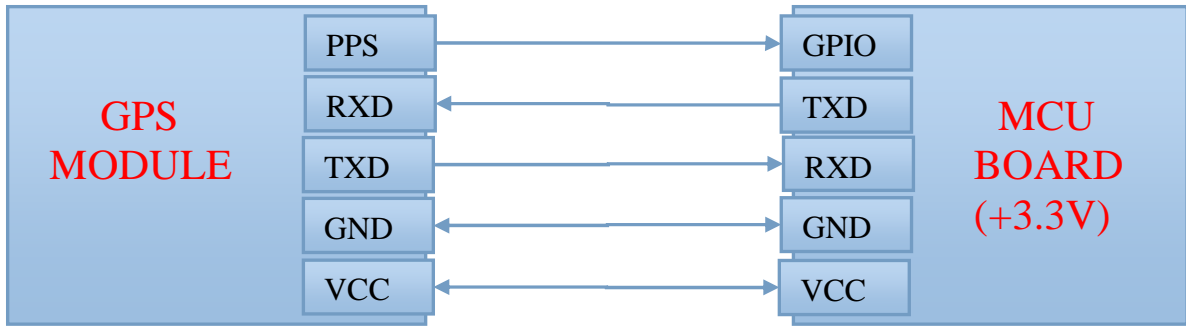

4.4 Connect to 5V Arduino Board

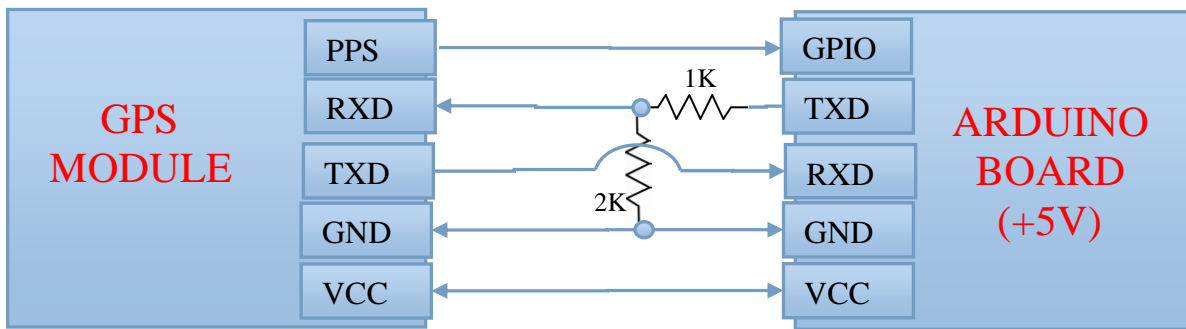

4.5 Connect to PC

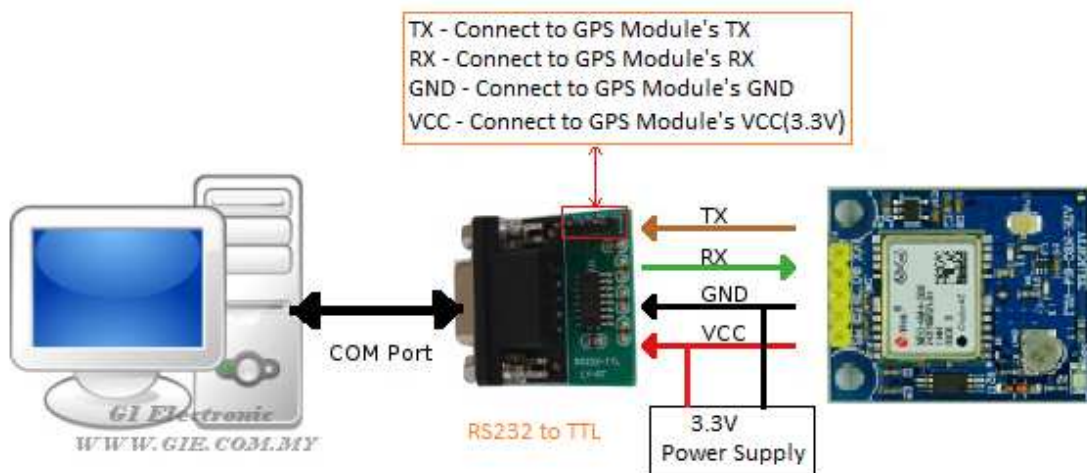

4.6 NMEA Protocol

NMEA messages sent by the GPS receiver are based on NMEA 0183 Version 2.3. The following picture shows the structure of a NMEA protocol message.

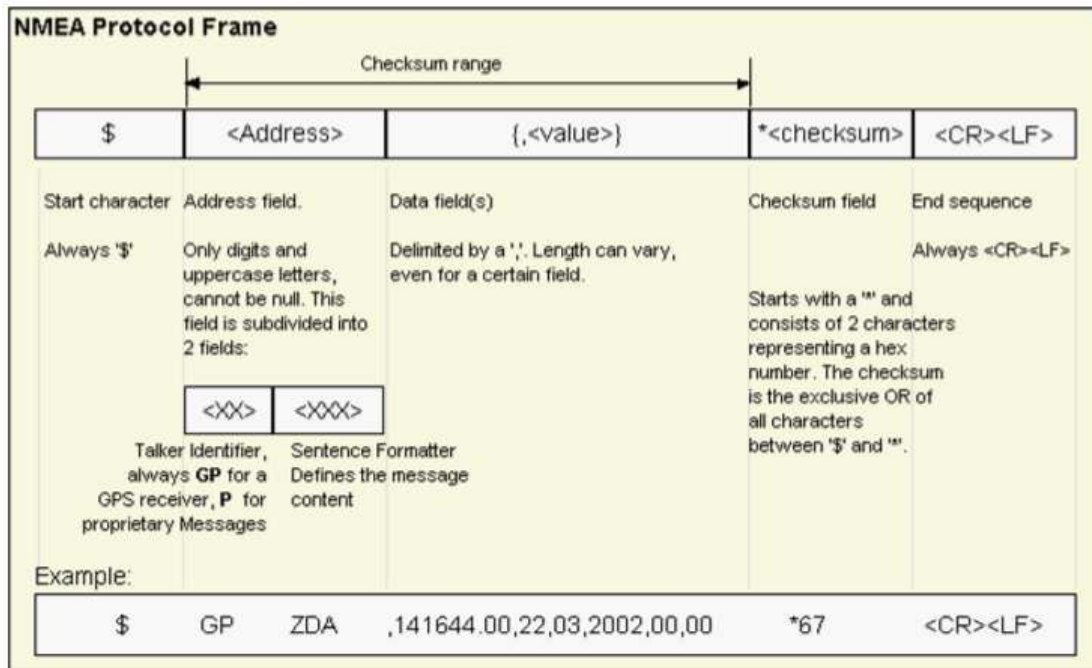

4.6.1 Reference documentation

- (i) http://en.wikipedia.org/wiki/NMEA_0183
- (ii) http://www.u-blox.com/images/downloads/Product_Docs/u-blox6_ReceiverDescriptionProtocolSpec_%28GPS.G6-SW-10018%29.pdf

4.7 Using u-center

The u-center GNSS evaluation software provides a powerful tool for evaluation, performance analysis and configuration of u-blox GNSS receivers. Its unique flexibility makes the u-center GNSS evaluation software an invaluable tool for evaluation, analysis and configuration of u-blox GNSS receivers. u-blox GNSS receivers can be configured using the u-center evaluation software.

You can download from

https://www.u-blox.com/images/Support/Support_Products/EvaluationSoftware/u-centersetup_v8.10.zip

5. Note

5.1 GPS module was built with a ceramic antenna, however it must facing to the sky or it may not receive GPS signals.

5.2 If you want to use the module indoor, you need a external active antenna to put outside the window to achieve positioning.

6. Kit Contents

- a.) U-Blox Neo-6M GPS Module x1

7. Warranty

- a.) Product warranty is valid for 3 months.
- b.) Warranty is only applies to manufacturing defect.
- c.) Damage caused by improper use is not cover under warranty.
- d.) Warranty does not cover freight cost for both ways.